

ENCORE™ SINK

PRODUCT INSTRUCTIONS



POLYJOHN®
there when you need us



NOTE: We recommend reading through the entire Assembly Instructions prior to proceeding with use, service or maintenance.

PRODUCT SPECIFICATIONS

ENCORE™ SINK
PSW3-1000



DIMENSION	IMPERIAL	METRIC
Height	62 in.	157.5 cm
Width	18 in.	45.5 cm
Depth	20 in.	50.8 cm
Fresh Water Capacity	15.5 gal	58.7 L
Gray Water Capacity	19 gal	72 L
Pump Capacity (per stroke)	2 fl. oz	59.14 ml
Soap Dispenser Capacity	30 fl. oz	887 ml
Number of Single Dispenses	992	992
Weight Empty	47 lb.	21.3 kg.
Weight Full	177 lb.	80 kg.

Paper Towel Dispenser

1 Roll or 500 Single Fold
(2 packs - Georgia Pacific 23504)

NOTE: All dimensions are subject to change due to environmental factors. All materials, including resin, pigments and additives used to make the plastic components as well as the plumbing components that come in contact with the fresh water are U.S. FDA food grade compliant.

IMPORTANT DECALS

- **NOT FOR DRINKING OR COOKING:** is required by law in certain areas of the U.S. Other geographical areas require that the materials used to manufacture the sinks comply with the U.S. Federal Food and Drug Administration (FDA) guidelines 21 CFR 175.300 (resins), 177.1520 (olefin polymers) and 178.3297 (colorants for polymers). The materials also comply with the U.S. Public Health Service Drinking Water Standards, 42 CFR part 72 and U.S. Environmental Protection Agency Interim Primary Drinking Water Regulations 40 CFR part 141.
- **HANDS FREE PUMP:** instruction for user to use foot pump to operate the sink.
- **UNIT MUST BE DRAINED BEFORE TRANSPORTING:** reminds service operator to empty the sink before transporting.

PRODUCT OVERVIEW

ENCORE™ SINK
PSW3-1000

The PSW3-1000 Encore™ sink is easily transportable fresh water sink with a built-in handle and rubber treaded wheels. Designed for use where convenient hand washing is desired or required, such as offices, classrooms, construction sites, festivals, food service locations, etc., to be used indoors or out. The compact design allows it to be used most anywhere. Ideal where space is limited. Shipped fully assembled.

SERVICE AND MAINTENANCE

FILLING WITH FRESH WATER

Unscrew the fill plug located at the top, left hand side of the wash basin by pushing down and turning counter clockwise 1/4 turn. Insert a standard 3/4" garden or similar type hose and fill with a few gallons of fresh water to perform a system check. Depress the pump a few times to "prime" it (the pump has a built-in check valve that will hold a prime between uses). If needed, continue filling to the top (which is the 15.5 gallon water level capacity). Tighten the plug when finished.

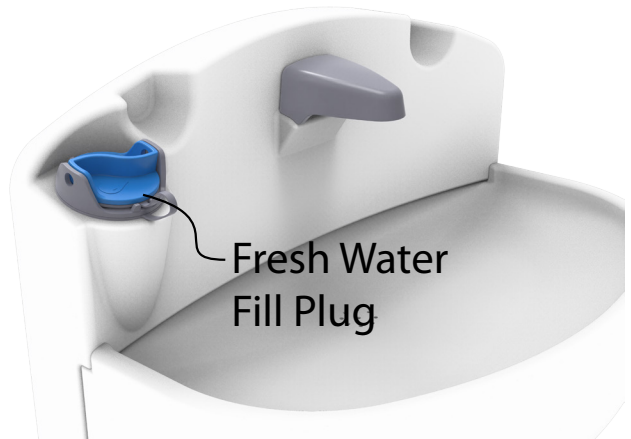

EMPTYING FRESH WATER

Drain the fresh water by unscrewing the plug located at the bottom of the sink by 1/4 turn. Tighten the plug when finished.



EMPTYING GRAY WATER

Wheel the sink to a proper and approved drain location. Pull the hose out from the rib on the back of the holding tank, remove the hose cap and empty the gray water. Replace the cap when finished. The contents of the gray water could also be sucked out through the hatch at the top of the sink.

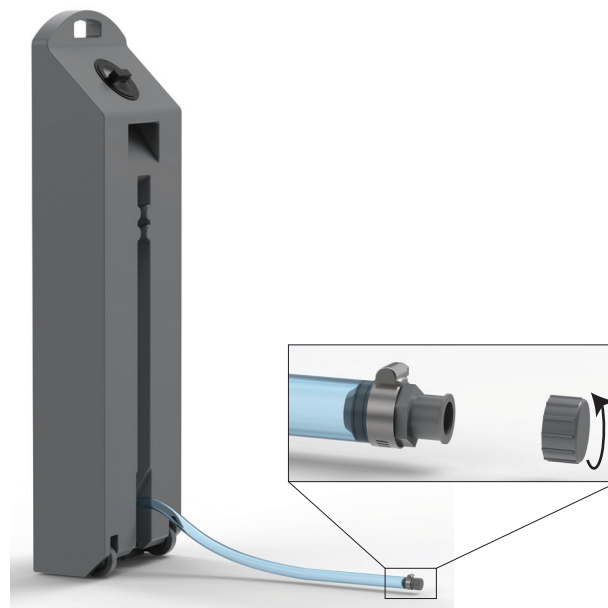

SERVICE AND MAINTENANCE

ENCORE™ SINK
PSW3-1000

PAPER TOWEL DISPENSER

These dispensers are designed to accept towels that are no wider than 9-1/2" wide, whether using single, multi-fold, or a roll towel. The recommended towels are the Georgia Pacific #23504 - single fold towel or the Tork RK350A - roll towel.

OPENING THE PAPER TOWEL DISPENSER

Position your hands on both sides of the dispenser cover (as shown). While pulling out on both sides lift up the cover and pull down towards yourself.

FILLING THE DISPENSER

Filling with Fold Towels: Place the package of towels on the towel tray with the fold of the towel facing downward. Pull the first towel through the middle opening of the paper towel tray. Close the cover.

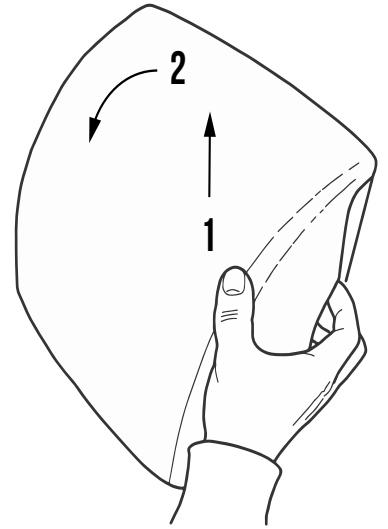
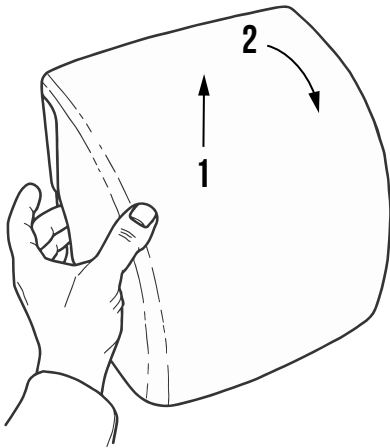

FILLING WITH A ROLL OF TOWELS

Place the roll of towels on the spindle with the roll of towels coming off towards you with the arrow end of the spindle facing towards the right. Place the spindle into the right side of the dispenser first. Place the left side of the spindle into the groove on the left side of the dispenser and push down in place. Feed the roll of towels over the front of the paper towel tray. Close the cover.

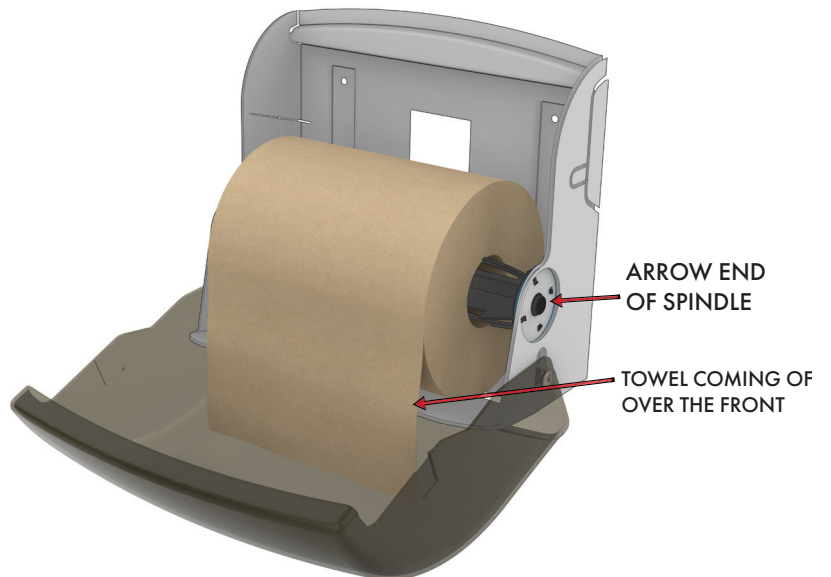

SOAP DISPENSER FILL

To do this, start by turning the lid of the dispenser counterclockwise and remove. Then, push in the locking tab at the rear of the dispenser and push up on the soap container, separating the container from the mounting plate.

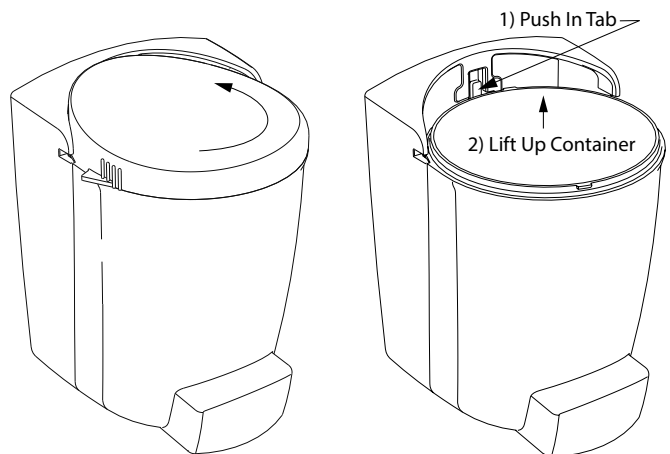

PARTS DIAGRAM EXPLODED VIEW

ENCORE™ SINK PSW3-1000

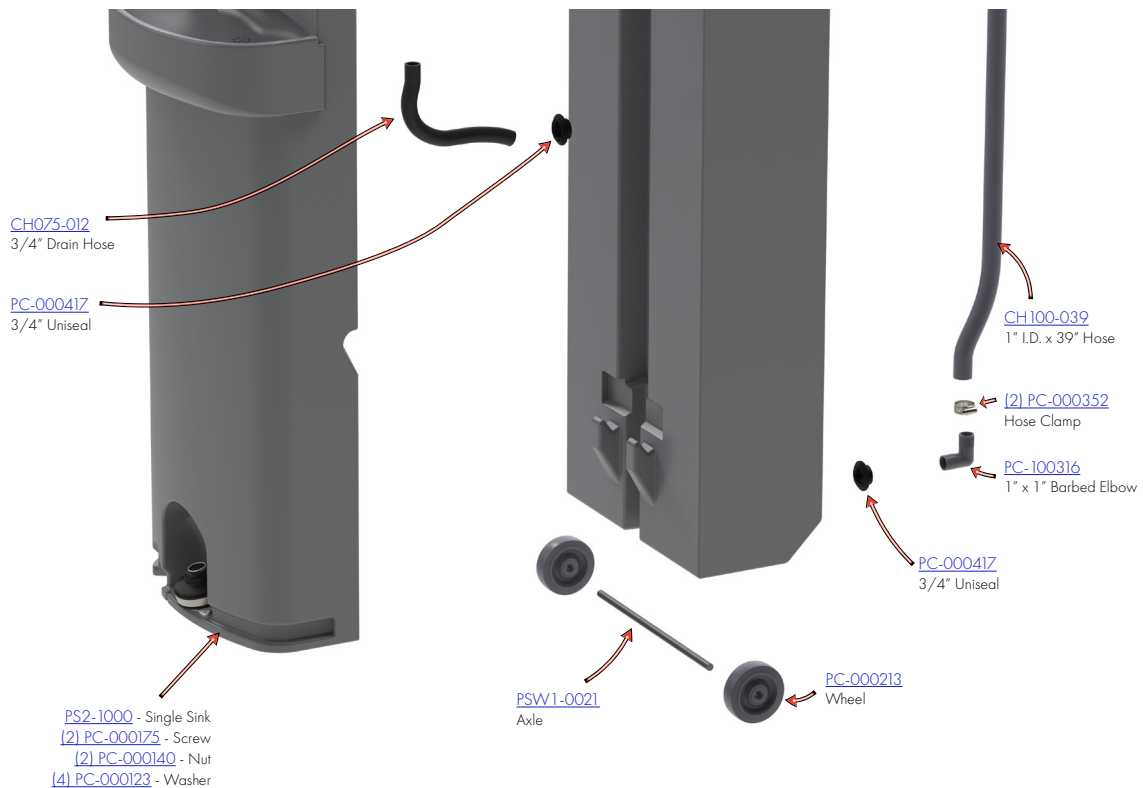
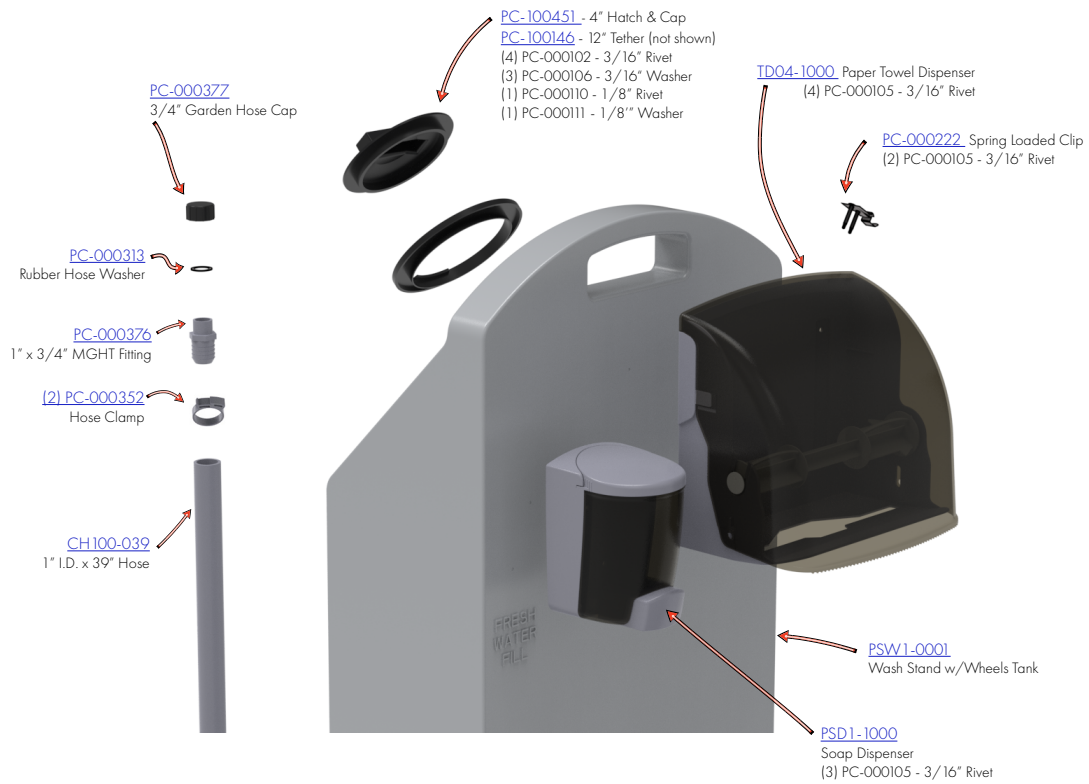

PARTS DIAGRAM EXPLODED VIEW

ENCORE™ SINK PSW3-1000

ITEMS NOT SHOWN

- [PC-000782](#) - Decal Not for Drinking or Cooking
- [PC-000783](#) - Decal Transport
- [PC-000790](#) - Decal Foot Pump
- [PC-000795](#) - Serial ID Plate
- (2) [PC-000105](#) Rivets

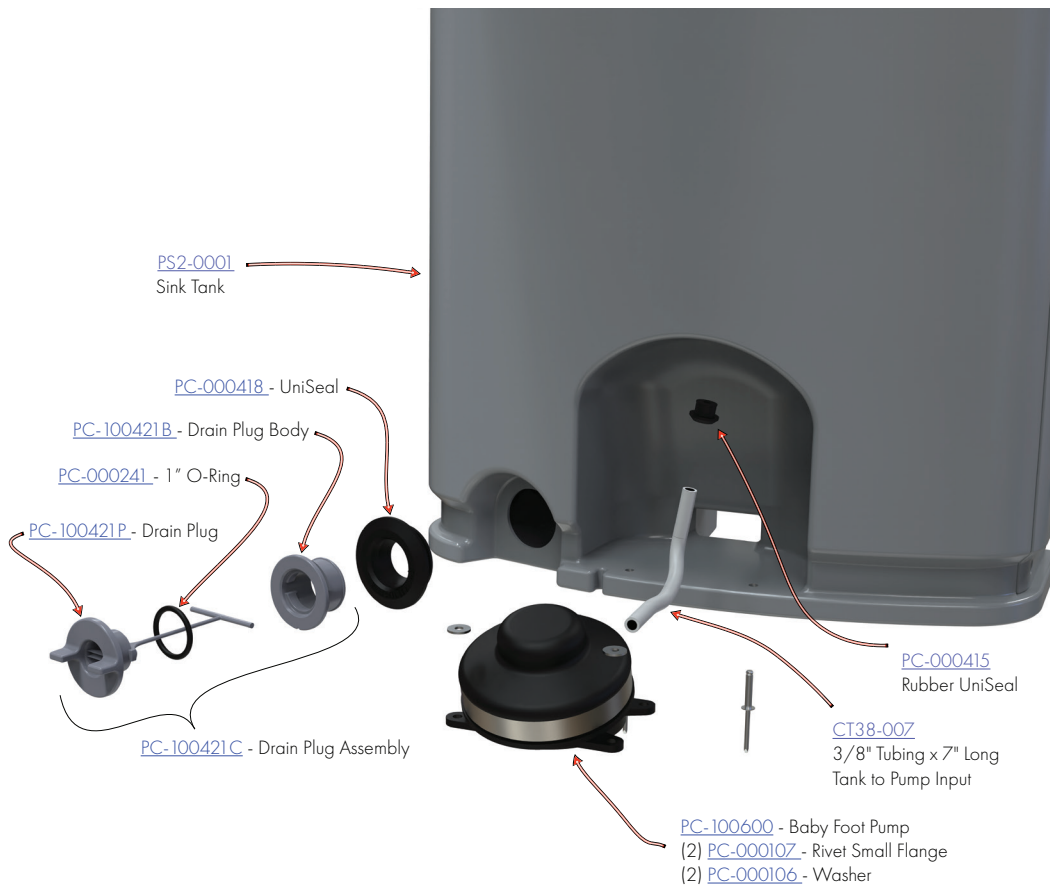
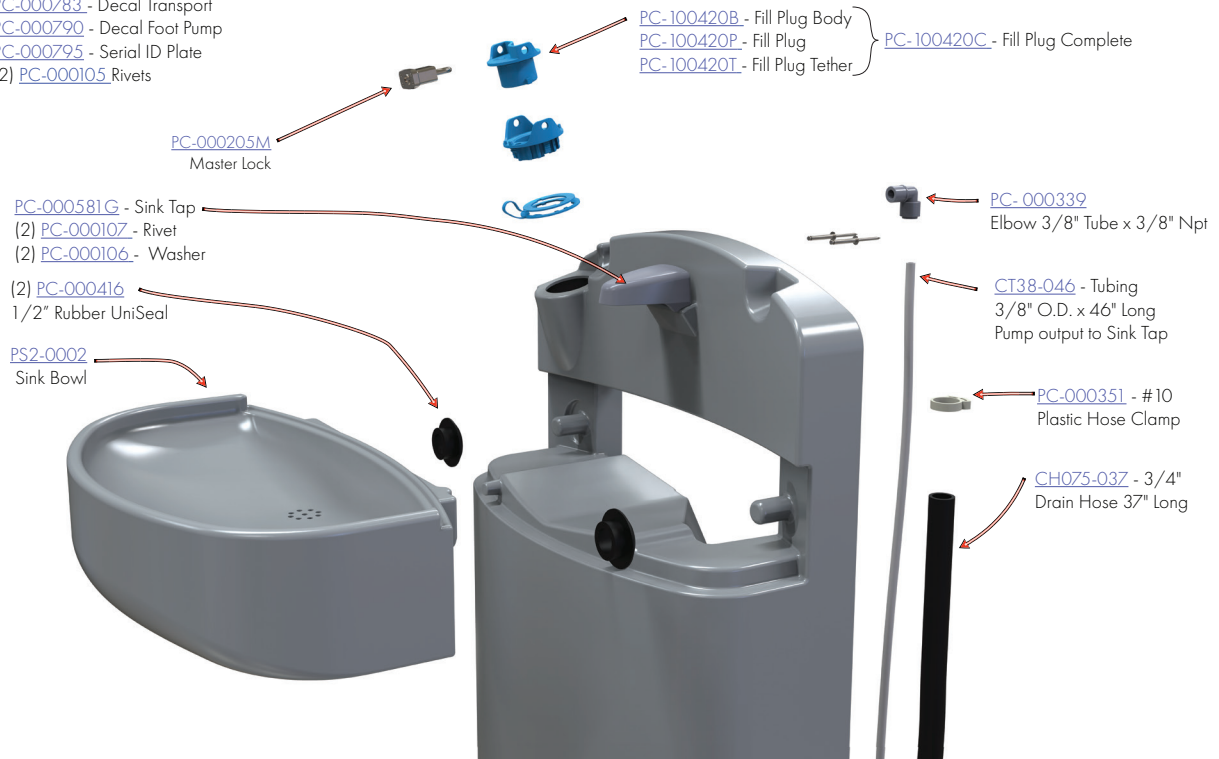

OPTIONAL ACCESSORIES, SUPPLIES AND CHEMICALS

ENCORE™ SINK
PSW3-1000



Liquid Soap Dispenser
PSD1-1000



Lotion Hand Soap
LS00-1000



Paper Towel Dispenser
TD04-1000

CLEANING AND MAINTENANCE

Use a mild soap to clean all surfaces and component parts.

Minor scratches and abrasions can be lightly sanded or scrubbed with a mild abrasive cleaner (such as "Soft Scrub") that contains calcium carbonate, hypochlorate bleach, and detergents. Be sure to follow the cleaning product directions since these ingredients may cause hazardous gases when mixed with other chemicals. Rinse the cleaned areas and buff with a conventional wax.

Some light scratches may also be hidden by using an industrial hot air gun.

For a source of cleaning, deodorizing and paper products contact:

PRO'S CHOICE
2500 GASPAR AVE.
WHITING, IN 46394-2175
800-292-1305
www.polyjohn.com/supplies/pros-choice.html

We highly recommend membership in the Portable Sanitation Association International (PSAI); the worldwide authority on portable sanitation services. The PSAI, "Portable Sanitation Industry Certification Program" manual contains a wealth of information on standards and service procedures. For more information contact the PSAI:

PORTABLE SANITATION ASSOCIATION INTERNATIONAL (PSAI)
7800 METRO PARKWAY, SUITE 104
BLOOMINGTON, MINNESOTA 55425 USA
800-822-3020 / 612-854-8300 FAX 612-854-7560
www.psa.org

Prop 65

PolyJohn Corporation would like to inform any customers or end users that some products may contain chemicals listed in California's Safe Drinking Water & Toxic Enforcement Act of 1986. Commonly referred to as Proposition 65, this Act establishes a list of chemicals known by the State of California to present a risk of cancer, birth defects, or other reproductive harm.

Chemical exposure typically occurs through inhalation, ingestion, or adsorption. PolyJohn products are not intended to be used in these methods. PolyJohn Corporation cannot foresee all uses of their products (both intended and unintended uses) and as a result has opted to provide a general warning of known chemical presence.

The Proposition 65 chemical list can be found at <http://www.P65Warnings.ca.gov>

The following warnings are labels placed on affected products. If these labels are not present then they do not apply to that product.

 **WARNING:** This product can expose you to chemicals including 4-Vinylcyclohexene which is known to the State of California to cause cancer and birth defects or other reproductive harm. For more information go to www.P65Warnings.ca.gov.

4-Vinylcyclohexene label above to be used any product made with Bayblend T85

 **WARNING:** This product can expose you to chemicals including titanium dioxide, which is known to the State of California to cause cancer. For more information go to www.P65Warnings.ca.gov.

Conflict Minerals Compliance Statement

Section 1502 of the Dodd-Frank Wall Street Reform and Consumer Protection Act, and the Securities and Exchange Commission Rules adopted in connection therewith, require certain corporations to report the use of "Conflict Minerals" in the manufacture of their products. Generally, Conflict Minerals collectively refers to cassiterite, columbite-tantalite, gold, wolframite, or their derivatives, including tantalum, tin and tungsten, which originate from the Democratic Republic of the Congo or specified adjoining countries (referred to herein as "Covered Countries").

While we, as a privately held corporation, are not subject to the Conflict Minerals rules and reporting requirements, we understand that our customers may be, and we are committed to helping our customers comply with their reporting requirements. In order to determine if our manufactured products contain Conflict Minerals, we have asked our relevant suppliers, as of September 1, 2020, to ascertain their use of any Conflict Minerals in the materials they supply to us. Their responses demonstrate that our relevant suppliers (i) do not use Conflict Minerals in the materials they supply to us, (ii) have no reason to believe the Conflict Minerals they use may have originated in the Covered Countries, and/or (iii) reasonably believe that the Conflict Minerals they use are from recycled or scrap sources. Consequently, we can in turn represent that, to the best of our knowledge, our manufactured products either do not contain Conflict Minerals, or to the extent they may, such products are "DRC conflict free" as defined by paragraph (e)(4) of Section 1502.

We will continue to work with our key suppliers to ensure that we are able to identify the use of Conflict Minerals in our supply chain, and the representations made in this compliance statement remain accurate. To that end, we reserve the right to amend this statement at any time based on subsequent developments or information.

Should you have any questions or concerns regarding this statement, please do not hesitate to contact us.

REACH Compliance

We certify that all components of the PolyJohn PSW3-1000 conform to REACH standards.

Specifically, we cite Article 7 of the Standard which indicates as follows:

Article 7(1) requires Producers and Importers of products to register with the ECHA chemical substances that are intentionally released from the products during use.

-No chemical substances are intentionally released from the product during use.

Article 7(2) requires Producers and Importers of products to notify the ECHA of the content of Substances of Very High Concern (SVHCs) if the concentration of SVHC is above 0.1% weight by weight (w/w) and the total amount put on the EU market by the subject company is more than 1 ton a year.

-No SVHC's exist in concentrations above 0.1% weight to weight (w/w) in the product.

We will maintain adequate documentation of this certification for inspection upon request.

Reduction of Toxics in Packaging

We certify that all packaging and packaging components comply with the requirements of the toxics in packaging law(s). Specifically: U.S. Toxics in Packaging Clearinghouse Standard and/or The European Parliament and Council Directive 94/62/EC of 20 December 1994 on packaging and packaging waste last amended by Directive 2018/852.

- 1) We certify that the regulated chemicals – lead, mercury, cadmium, and hexavalent chromium were not intentionally added to any package or packaging component during the manufacturing process.
- 2) We further certify that the sum of the incidental concentration levels of lead, mercury, cadmium and hexavalent chromium present in any package or package component does not exceed acceptable levels of parts per million by weight.
- 3) We further certify that no materials used to replace the regulated chemicals are present in a quantity or manner that creates a hazard as great as or greater than the hazard created by the regulated chemicals.
- 4) We will maintain adequate documentation of this certification for inspection upon request.

FREQUENTLY ASKED QUESTIONS

ENCORE™ SINK
PSW3-1000

Sinks

Q: How do I know if my sink is full?

A: There is not a fill level indicator on the sinks. So you either have to view down into the fill port or wait until you see water come from the top of the unit. There are also some units with a weep hole that will show when you have reached the highest-level capacity.

Q: My sink is leaking, what do I do?

A: Many times, there might not be a leak. Water displacement can cause sink to appear to be leaking. There is a weep hole on some units and if the water capacity goes past that level the water will leak out that hole. It could be that the water is too high. There is also the possibility that water was filled into the sink and then tipped back to transport. If its leaned too far back, then water can come out of the revert holes at the very top of the unit. That being said, there is always a very small chance that there is a manufacturing defect. If all other options have been ruled out, then please visit the PolyJohn Warranty page.

Q: Where is the fill port?

A: Most of our sinks fill ports are colored blue to indicate fresh water. They will be located towards the middle of the unit.

Q: How do I drain my water from the sink?

A: It depends on what sink model you own, but most of them have a fresh water drain port and a gray water drain port at the bottom. Some units like the 4 person wash station and the Encore models have a 4" port that can be suctioned out by a portable toilet operator.

Q: Where do I empty my gray water from the sink?

A: There are certain drains that you should not dump your gray water into. Storms drains for instance. Sewer drains are acceptable. You should always check your localities for regulations for all dumping including that of gray water.

RESTROOMS AND TOILETS

POLYJOHN PORTABLE RESTROOMS LIMITED 3 YEAR PRODUCT WARRANTY

PolyJohn Enterprises Corp. warrants the major plastic parts of its portable restrooms (plastic front, wall panels, roof, and tank) against any breakage or other problems that prevent the PolyJohn portable toilet from functioning in accordance with usual practices used in the portable toilet industry and in their intended manner. This warranty covers any damages in material or workmanship for a total period of 3 years (36 months). This warranty extends only to the original purchaser of the PolyJohn portable restroom. Proof of purchase, serial numbers, and photos will be required.

SINKS, TANKS, TRAILERS AND SANISTANDS

PolyJohn Enterprises warrants our sinks, tanks, trailers and sanistands from the date of purchase. Any misuse or abuse of our products or failure to properly follow recommended procedures shall void this warranty. The warranty is a 1 year limited warranty and a 90 day limited warranty for components thereof.

What is Not Covered By Warranty

This warranty does not cover damage or failure contributed to or caused by: Not following PolyJohn assembly procedures, unauthorized modification, acts of God, mishandling, misuse, use of incompatible solvents or other damaging chemicals, vandalism or accident. In no event shall PolyJohn be liable for labor costs or for incidental or consequential damages.

For full details on PolyJohn's warranty policy, and to view instructions for submitting a claim please visit <https://www.polyjohn.com/warranty/>.

Warranty Disclaimer

PolyJohn's terms of sale are FOB (Free on Board Shipping Point). Meaning buyer takes on responsibility once it leaves PolyJohn's shipping dock. The carrier is wholly responsible for any damage incurred during transit. Important notice: All concealed/non-notated damages must be reported within 5 business days of delivery (1st day is the day of delivery) as per the National Motor Freight Classification (NMFC) – Rule 300100 - for a damaged claim to be filed. Reporting after this time will void a claim.

In order to prevent warranty disputes follow these steps immediately when receiving your products:

Inspect the shipment immediately and insist that visible damages be indicated on your copy of the freight bill. If they are not noted on the freight bill it is very likely a claim will be denied.

Open the shipment if necessary, and inspect for any concealed damages.

If there are any damages that you cannot operate with you may refuse shipment. After you do this contact us immediately

Filing Process for Warranty

PolyJohn reserves the right to request inspection of products for verification of defect, which may include returning some or all of the parts with shipping paid for by the purchaser. Once the items have been returned, inspected, and PolyJohn is found at fault shipping costs will be reimbursed. You may contact PolyJohn to arrange for return shipping if desired.

To file your warranty claim follow these steps:

1. Go to [polyjohn.com/warranty/](https://www.polyjohn.com/warranty/)
2. Fill out necessary contact information
3. Fill in invoice number, date of purchase, product, and product serial numbers.
4. Upload an images of affected products
5. Submit and someone will be in contact with you as soon as possible.

OUR MISSION STATEMENT

“PolyJohn is a family owned, state of the art, plastics manufacturing company dedicated to providing its employees with a work environment committed to excellence, and its customers with innovative products, services and technology that meet or exceed their requirements.”

THANK YOU FOR PURCHASING POLYJOHN PRODUCTS!



POLYJOHN[®]
there when you need us

POLYJOHN USA
+1 800-292-1305
Whiting, Indiana
www.polyjohn.com

POLYJOHN INTERNATIONAL
UNITED KINGDOM
+44 (0) 1937-583333
Yorkshire, England
www.polyjohn.co.uk

POLYJOHN CANADA
+1 800-465-9590
Oro Medonte, Ontario
www.polyjohn.ca
www.fr.polyjohn.ca

POLYJOHN LATIN AMERICA
+01 800-953-1307
Chihuahua, Mexico
www.polyjohn.mx

POLYJOHN AUSTRALIA
+61 7 3277 5727
Brisbane, Australia
www.totalsanitationsolutions.com.au

POLYJOHN SOUTHERN AFRICA
+27 (011) 615-3804
Johannesburg, South Africa
www.polyjohn.co.za

POLYJOHN NEW ZEALAND
+64 (0)22 387 7142
Auckland, New Zealand
www.polyjohn.co.nz

POLYJOHN SOUTH AMERICA
+57 318 696 7744
Bogotá, Colombia
www.polyjohn.com

POLYJOHN INTERNATIONAL
CZECH REPUBLIC
+420 608 876 983
Karlovy Vary, Czech Republic
www.polyjohn.eu