

# 250 GALLON HOLDING TANK

## PRODUCT INSTRUCTIONS

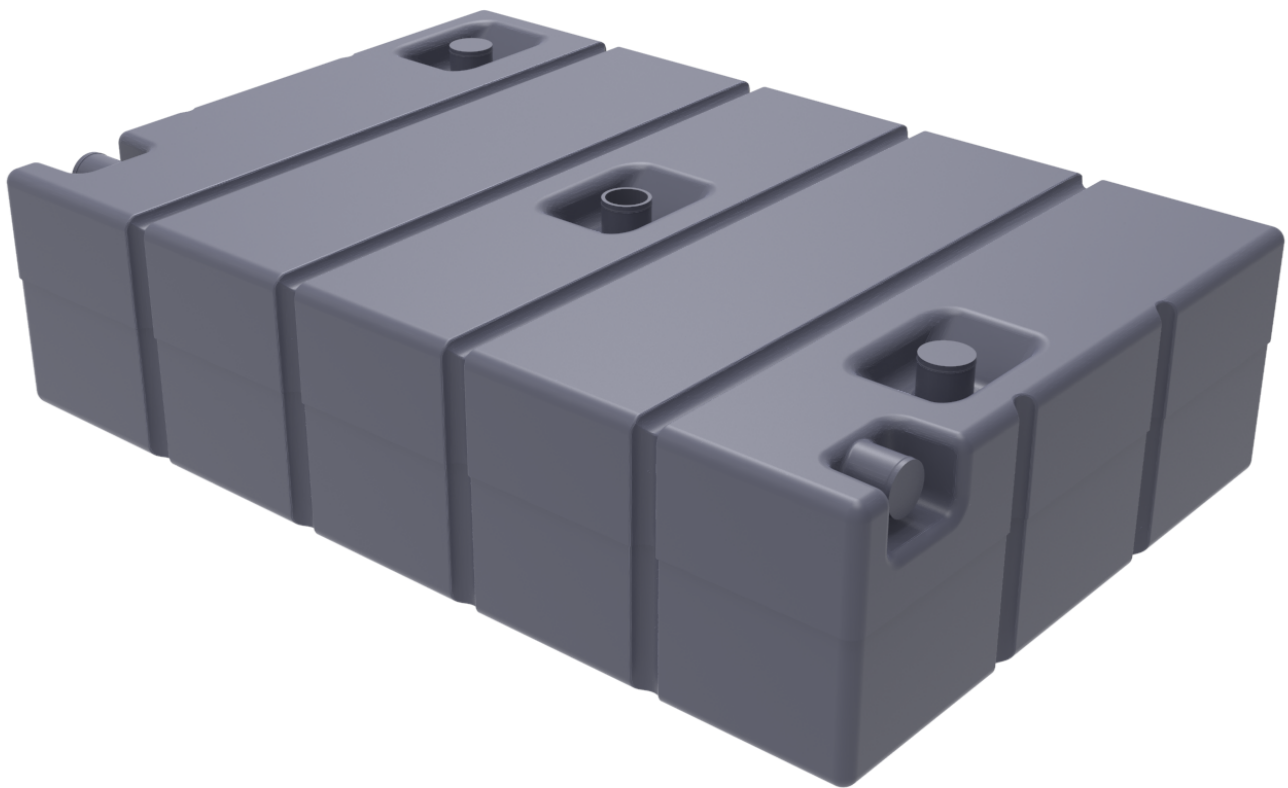

**POLYJOHN**<sup>®</sup>  
there when you need us



### General Overview

These unique portable holding tanks were designed to be used primarily above ground, but with special accommodations, they may be used slightly below grade where allowed by local regulations. They have a nominal wall thickness of 1/4" and are very durable and resistant to impacts. The resin and color pigments are FDA food grade compliant. They eliminate the use of threaded and solvent-cemented conventional plumbing fittings, which are usually discarded after each use. The 3" (7.6cm) ports utilize "Fernco"<sup>®</sup> flexible rubber couplings, which are available in a variety of pipe sizes and plumbing configurations such as couplers, elbows, tees and caps. These flexible fittings are re-usable. These durable plastic polyethylene tanks are supplied with the top, center port #4, cut open with a 3" rubber cap and clamp provided. Other ports can be cut open and a rubber cap and clamp supplied at the customer's request for a nominal fee.

# TECHNICAL INFORMATION

HT01-0250  
250 GALLON HOLDING TANK

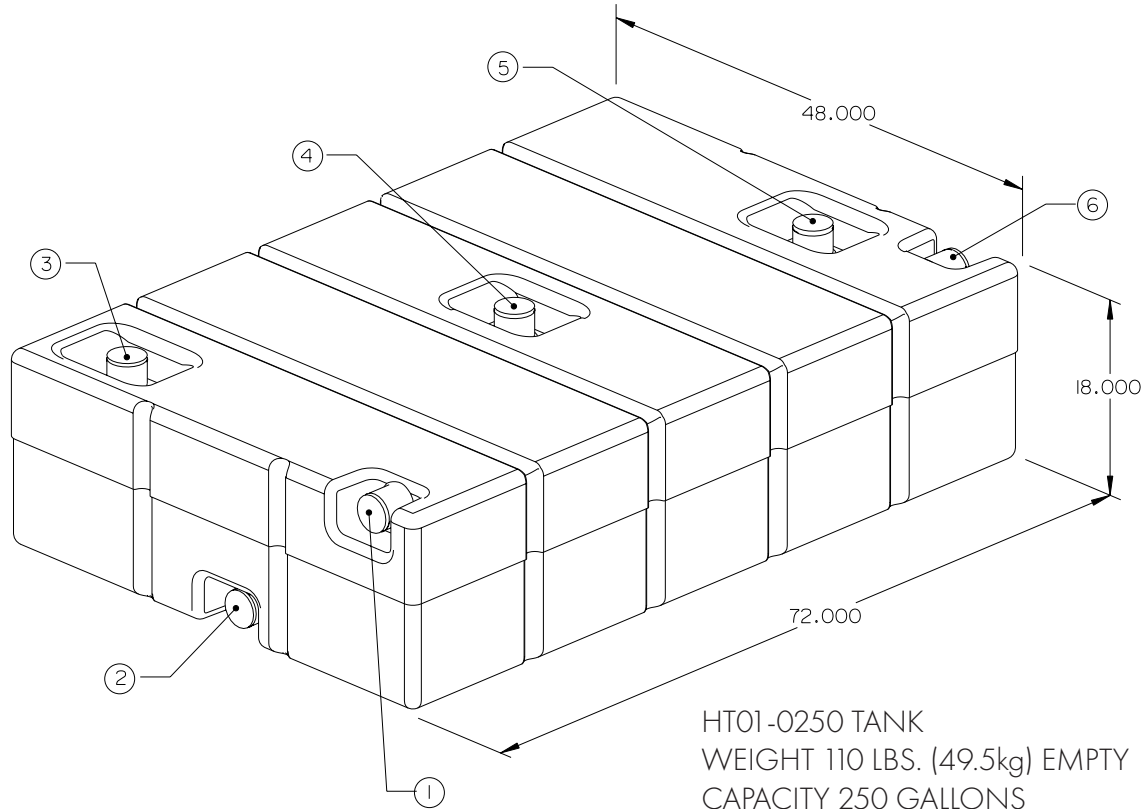

Quantity	Port 1	Port 2	Port 3	Port 4	Port 5	Port 6
				X		
				X		
				X		
				X		
				X		
				X		

## TOOLS REQUIRED TO PLUMB TANKS TO SEWAGE CONNECTION



2-3/4" (70mm)  
Hole Saw



Drill

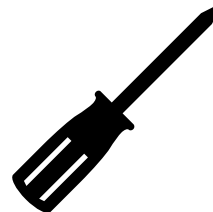

Standard Slotted  
Screwdriver



OR

Socket Wrench  
with a 5/16" socket

## RESTROOMS AND TOILETS

### POLYJOHN PORTABLE RESTROOMS LIMITED 3 YEAR PRODUCT WARRANTY

PolyJohn Enterprises Corp. warrants the major plastic parts of its portable restrooms (plastic front, wall panels, roof, and tank) against any breakage or other problems that prevent the PolyJohn portable toilet from functioning in accordance with usual practices used in the portable toilet industry and in their intended manner. This warranty covers any damages in material or workmanship for a total period of 3 years (36 months). This warranty extends only to the original purchaser of the PolyJohn portable restroom. Proof of purchase, serial numbers, and photos will be required.

## SINKS, TANKS, TRAILERS AND SANISTANDS

PolyJohn Enterprises warrants our sinks, tanks, trailers and sanistands from the date of purchase. Any misuse or abuse of our products or failure to properly follow recommended procedures shall void this warranty. The warranty is a 1 year limited warranty and a 90 day limited warranty for components thereof.

### What is Not Covered By Warranty

This warranty does not cover damage or failure contributed to or caused by: Not following PolyJohn assembly procedures, unauthorized modification, acts of God, mishandling, misuse, use of incompatible solvents or other damaging chemicals, vandalism or accident. In no event shall PolyJohn be liable for labor costs or for incidental or consequential damages. For full details on PolyJohn's warranty policy, and to view instructions for submitting a claim please visit <https://www.polyjohn.com/warranty/>.

### Warranty Disclaimer

PolyJohn's terms of sale are FOB (Free on Board Shipping Point). Meaning buyer takes on responsibility once it leaves PolyJohn's shipping dock. The carrier is wholly responsible for any damage incurred during transit. Important notice: All concealed/non-notated damages must be reported within 5 business days of delivery (1st day is the day of delivery) as per the National Motor Freight Classification (NMFC) – Rule 300100 - for a damaged claim to be filed. Reporting after this time will void a claim.

In order to prevent warranty disputes follow these steps immediately when receiving your products:

- Inspect the shipment immediately and insist that visible damages be indicated on your copy of the freight bill. If they are not noted on the freight bill it is very likely a claim will be denied.
- Open the shipment if necessary, and inspect for any concealed damages.
- If there are any damages that you cannot operate with you may refuse shipment. After you do this contact us immediately

### Filing Process for Warranty

PolyJohn reserves the right to request inspection of products for verification of defect, which may include returning some or all of the parts with shipping paid for by the purchaser. Once the items have been returned, inspected, and PolyJohn is found at fault shipping costs will be reimbursed. You may contact PolyJohn to arrange for return shipping if desired.

To file your warranty claim follow these steps:

1. Go to [polyjohn.com/warranty/](https://www.polyjohn.com/warranty/)
2. Fill out necessary contact information
3. Fill in invoice number, date of purchase, product, and product serial numbers.
4. Upload an images of affected products
5. Submit and someone will be in contact with you as soon as possible.

# OUR MISSION STATEMENT

“PolyJohn is a family owned, state of the art, plastics manufacturing company dedicated to providing its employees with a work environment committed to excellence, and its customers with innovative products, services and technology that meet or exceed their requirements.”

THANK YOU FOR PURCHASING POLYJOHN PRODUCTS!



**POLYJOHN**<sup>®</sup>  
there when you need us

---

POLYJOHN USA  
+1 800-292-1305  
Whiting, Indiana  
[www.polyjohn.com](http://www.polyjohn.com)

POLYJOHN INTERNATIONAL  
UNITED KINGDOM  
+44 (0) 1937-583333  
Yorkshire, England  
[www.polyjohn.co.uk](http://www.polyjohn.co.uk)

POLYJOHN CANADA  
+1 800-465-9590  
Oro Medonte, Ontario  
[www.polyjohn.ca](http://www.polyjohn.ca)  
[www.fr.polyjohn.ca](http://www.fr.polyjohn.ca)

POLYJOHN LATIN AMERICA  
+01 800-953-1307  
Chihuahua, Mexico  
[www.polyjohn.mx](http://www.polyjohn.mx)

POLYJOHN AUSTRALIA  
+61 7 3277 5727  
Brisbane, Australia  
[www.totalsanitationsolutions.com.au](http://www.totalsanitationsolutions.com.au)

POLYJOHN SOUTHERN AFRICA  
+27 (011) 615-3804  
Johannesburg, South Africa  
[www.polyjohn.co.za](http://www.polyjohn.co.za)

POLYJOHN NEW ZEALAND  
+64 (0)22 387 7142  
Auckland, New Zealand  
[www.polyjohn.co.nz](http://www.polyjohn.co.nz)

POLYJOHN SOUTH AMERICA  
+57 318 696 7744  
Bogotá, Colombia  
[www.polyjohn.com](http://www.polyjohn.com)

POLYJOHN INTERNATIONAL  
CZECH REPUBLIC  
+420 608 876 983  
Karlovy Vary, Czech Republic  
[www.polyjohn.eu](http://www.polyjohn.eu)